

WWB 0300-0900

Water-water heat pumps only

Heating capacity 56,7 ÷ 265,9 kW

- Optimised to produce high temperature hot water
- Can be used with any air or water cooled heat pump
- Max. processed water temperature: 80 °C
- Max inlet temperature on source side: 45 °C



DESCRIPTION

WWB is a range of irreversible water-water heat pumps that produce high temperature water with a low or medium temperature source. Internal unit suitable for use in centralised residential systems, in systems that serve hotels and other forms of accommodation, and for applications in the tertiary and industrial sectors.

FEATURES

Maximum energy efficiency

Aermec, which has focused for years on energy efficiency, designed the WWB units with the aim of guaranteeing high efficiency both with full and partial loads.

Operating field

With its wide operating range, it can be integrated with numerous applications and is a valid alternative to boilers and all conventional systems used to produce high temperature hot water since it also uses existing systems.

Production of hot water up to 80 °C (Max inlet temperature on source side 45 °C).

Constructional characteristics of unit

- Optimised plate heat exchangers with low pressure drops.
- 2 cooling circuits, 1 compressor per circuit.
- Scroll compressors for high condensing temperatures.
- Compact size for easier installation.

The base the structure and the panels are made of steel treated with polyester paint RAL 9003.

Electronic expansion valve

The possibility to use electronic expansion valve, offers significant benefits, especially when the chiller is working with partial loads, increasing the energy efficiency of the unit.

CONTROL

Control unit accessible externally with touch-screen user interface, multilingual display of all operating parameters. Optimised control logic for use with low and medium temperature heat pumps.

Complies with safety (EC) and electromagnetic compatibility directives. **Removable slide-out electrical panel with opening side (LH/RH side) configurator option**

ACCESSORIES

AER485P1: RS-485 interface for supervision systems with MODBUS protocol.

AERNET: The device allows the control, the management and the remote monitoring of a Chiller with a PC, smartphone or tablet using Cloud connection. AERNET works as Master while every unit connected is configured as Slave (max. 6 unit); also, with a simple click is possible to save a log file with all the connected unit datas in the personal terminal for post analysis.

MULTICHILLER_EVO: Control, switch-on and switch-off system of the single chillers where multiple units are installed in parallel, always ensuring constant flow rate to the evaporators.

PGD1: Allows you to control the unit at a distance.

VT: Anti-vibration supports.

FACTORY FITTED ACCESSORIES

RIF: Power factor correction. Connected in parallel to the motor allowing about 10% reduction of input current.

ACCESSORIES COMPATIBILITY

Model	Ver	0300	0330	0350	0550	0600	0700	0800	0900
AER485P1	L	•	•	•	•	•	•	•	•
AERNET	L	•	•	•	•	•	•	•	•
MULTICHILLER_EVO	L	•	•	•	•	•	•	•	•
PGD1	L	•	•	•	•	•	•	•	•

MULTICHILLER_EVO: Contact the factory for compatibility of the accessory with the type of implant envisaged.

Antivibration

Ver	0300	0330	0350	0550	0600	0700	0800	0900
L	VT9	VT9	VT9	VT9	VT15	VT15	VT15	VT15

Power factor correction

Ver	0300	0330	0350	0550	0600	0700	0800	0900
L	RIFWWB0300	RIFWWB0330	RIFWWB0350	RIFWWB0550	RIFWWB0600	RIFWWB0700	RIFWWB0800	RIFWWB0900

A grey background indicates the accessory must be assembled in the factory

CONFIGURATOR

Field	Description
1,2,3	WWB
4,5,6,7	Size 0300, 0330, 0350, 0550, 0600, 0700, 0800, 0900
8	Operating field X Standard (1)
9	Model H Heat pump
10	Version

Field	Description
L	Silenced
11	Power supply ° 400V ~ 3 50Hz S 400V ~ 3 50Hz with Soft-Start
12	Electrical panel version ° Standard opening (LH) R Reverse opening (RH)

(1) Evaporator water up to +5°C. Electronic thermostatic valve as standard.

Example of four-pipe system

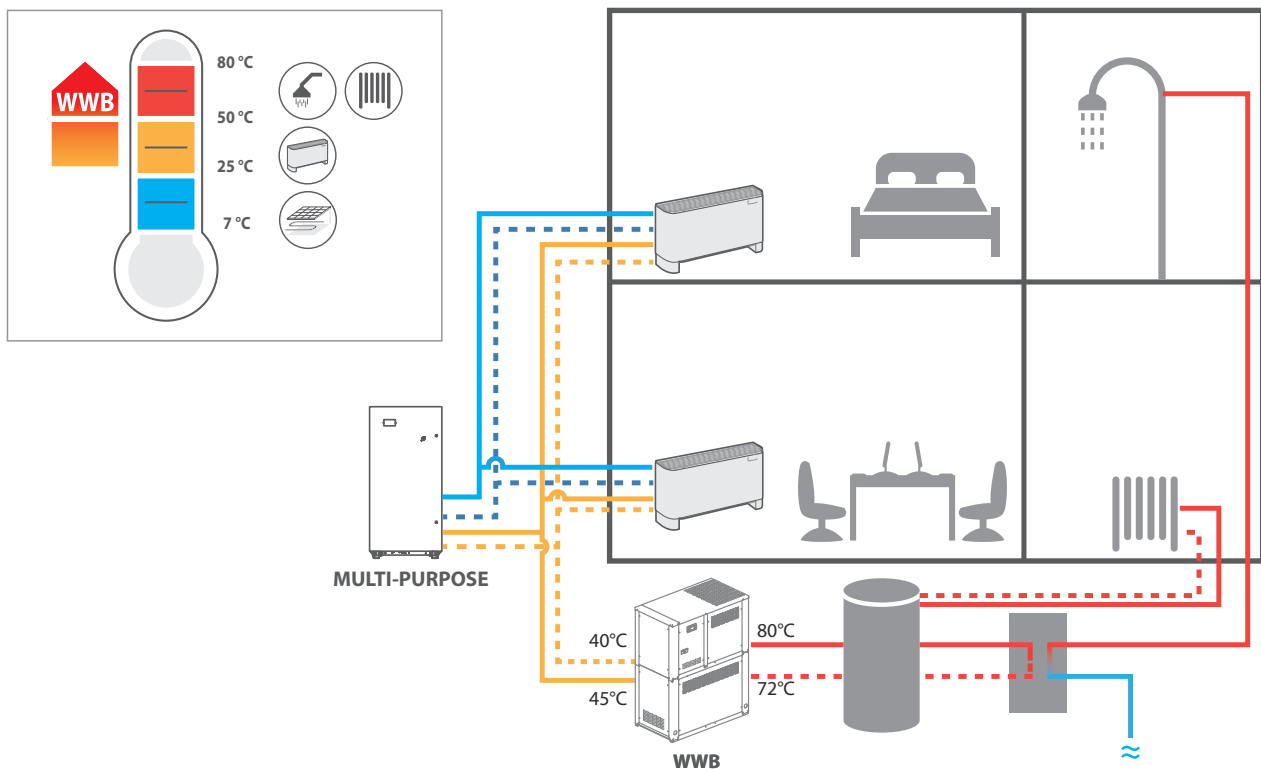

PERFORMANCE SPECIFICATIONS

Size			0300	0330	0350	0550	0600	0700	0800	0900
Heating performances (Water user side 70 °C / 78 °C; Water source side 45 °C / 40 °C) (1)										
Heating capacity	L	kW	70,3	77,7	93,2	114,6	143,7	181,7	220,5	265,9
Input power	L	kW	16,7	18,0	21,6	27,7	34,7	44,3	55,4	66,4
Heating total input current	L	A	29,0	30,0	36,0	46,0	61,0	71,0	89,0	104,0
COP	L	W/W	4,22	4,31	4,33	4,14	4,14	4,11	3,98	4,00
Water flow rate system side	L	l/h	7721	8537	10243	12592	15787	19973	24229	29221
Pressure drop system side	L	kPa	18	22	31	21	33	24	35	24
Water flow rate source side	L	l/h	9339	10400	12491	15141	18986	23950	28791	34785
Pressure drop source side	L	kPa	12	15	10	15	8	12	16	23
Heating performances (Water user side 70 °C / 78 °C; Water source side 35 °C / 30 °C) (2)										
Heating capacity	L	kW	56,7	62,7	75,2	92,4	115,9	146,5	177,8	214,4
Input power	L	kW	16,3	17,6	21,0	27,0	33,9	43,2	54,0	64,7
Heating total input current	L	A	28,0	29,0	35,0	45,0	59,0	70,0	87,0	102,0
COP	L	W/W	3,48	3,56	3,58	3,42	3,42	3,39	3,29	3,31
Water flow rate system side	L	l/h	6228	6886	8262	10157	12734	16110	19543	23570
Pressure drop system side	L	kPa	12	14	20	14	22	15	23	16
Water flow rate source side	L	l/h	7008	7820	9396	11340	14221	17924	21486	25974
Pressure drop source side	L	kPa	7	9	6	8	4	7	9	13

(1) Date 14511:2018; Water user side 70 °C / 78 °C; Water source side 45 °C / 40 °C

(2) Date 14511:2018; Water user side 70 °C / 78 °C; Water source side 35 °C / 30 °C

ENERGY DATA

Size			0300	0330	0350	0550	0600	0700	0800	0900
UE 813/2013 performance in average ambient conditions (average) - 55 °C - Pdesignh ≤ 400 kW (1)										
Pdesignh	L	kW	46	51	61	76	95	120	145	175
ηsh	L	%	176.0%	180.0%	180.0%	175.0%	174.0%	174.0%	169.0%	171.0%
SCOP	L		4,60	4,69	4,69	4,56	4,55	4,56	4,43	4,49
Efficiency energy class	L		A++	A++	A++	-	-	-	-	-

(1) Efficiencies for average temperature applications (55 °C)

ELECTRIC DATA

Size			0300	0330	0350	0550	0600	0700	0800	0900
Power supply: °										
Electric data										
Maximum current (FLA)	L	A	30,9	32,2	38,2	50,2	64,6	79,8	94,6	113,7
Peak current (LRA)	L	A	110,4	127,1	137,1	165,1	206,3	264,9	319,3	366,9
Power supply: S										
Electric data										
Maximum current (FLA)	L	A	30,9	32,2	38,2	50,2	64,6	79,8	94,6	113,7
Peak current (LRA)	L	A	53,4	60,5	66,3	81,1	101,9	129,9	156,1	180,9

GENERAL TECHNICAL DATA

Size			0300	0330	0350	0550	0600	0700	0800	0900
Compressor										
Type	L	type					Scroll			
Compressor regulation	L	Type					On-Off			
Number	L	no.	2	2	2	2	2	2	2	2
Circuits	L	no.	2	2	2	2	2	2	2	2
Refrigerant	L	type					R134a			
Refrigerant load circuit 1	L	kg	2,8	2,8	3,6	4,4	6,5	7,7	8,0	9,9
Refrigerant load circuit 2	L	kg	2,8	2,8	3,5	4,3	6,3	7,5	7,8	9,7
Source side heat exchanger										
Type	L	type					Brazed plate			
Number	L	no.	1	1	1	1	1	1	1	1
Connections (in/out)	L	Type					Grooved joints			
Sizes (in/out)	L	∅	2"	2"	2"	2"	2" 1/2	2" 1/2	2" 1/2	2" 1/2
System side heat exchanger										
Type	L	type					Brazed plate			
Number	L	no.	1	1	1	1	1	1	1	1
Connections (in/out)	L	Type					Grooved joints			
Sizes (in/out)	L	∅	2"	2"	2"	2"	2"	2"	2"	2" 1/2
Sound data calculated in cooling mode (1)										
Sound power level	L	dB(A)	71,8	71,8	71,8	75,1	78,3	79,3	80,4	82,4
Sound pressure level (10 m)	L	dB(A)	40,2	40,2	40,2	43,5	46,7	47,7	48,9	50,9

(1) Sound power calculated on the basis of measurements made in accordance with UNI EN ISO 9614-2, as required for Eurovent certification. Sound pressure (cold functioning) measured in free field, 10m away from the unit external surface (in compliance with UNI EN ISO 3744).

Removal of electrical panel

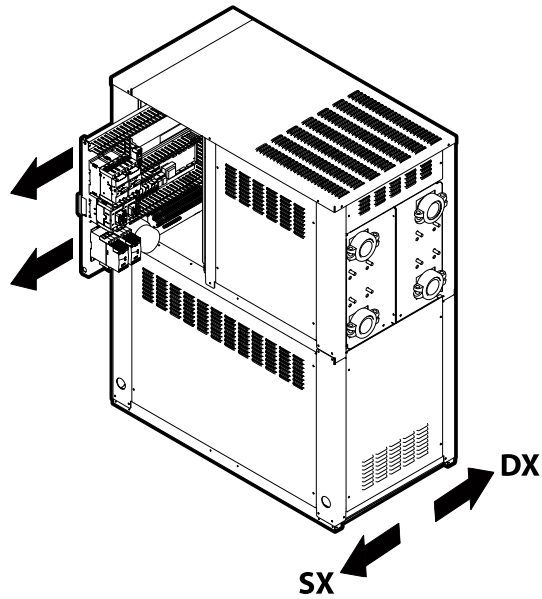

Electrical panel version		Configurator option
Sx - LH side		° (Standard)
Dx - RH side		R

DIMENSIONS

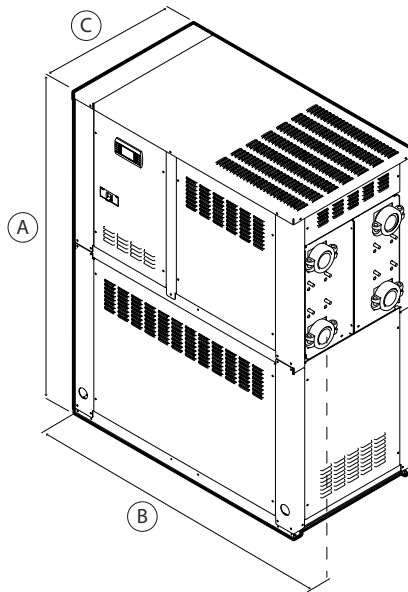

Size			0300	0330	0350	0550	0600	0700	0800	0900
Dimensions and weights										
A	L	mm	1650	1650	1650	1650	1650	1650	1650	1650
B	L	mm	1300	1300	1300	1300	1300	1300	1300	1300
C	L	mm	710	710	710	710	710	710	710	710
Weights										
Weight empty + packaging	L	kg	420	425	440	455	500	715	760	820
Weight functioning	L	kg	415	420	440	460	510	730	775	840

Aermec reserves the right to make any modifications deemed necessary. All data is subject to change without notice. Aermec does not assume responsibility or liability for errors or omissions.

Aermec S.p.A.

Via Roma, 996 - 37040 Bevilacqua (VR) - Italia
Tel. 0442633111 - Telefax 044293577
www.aermec.com